

e:cue

LIGHTING CONTROL

e:bus – short introduction manual

introduction

This document gives a short introduction to the new e:bus communication protocol. e:bus is a bus system developed by e:cue for a secure, bi-directional and fast system link between e:bus enabled user terminals.

advantages of the e:bus system

The e:bus networking platform offers several features that allows a simple installation and great reliability in practical installations.

- e:bus is a self-organizing network. This simplifies configuration through a plug & play – like behaviour. The addressing occurs automatically.
- Link power. User interfaces are directly powered over e:bus. Fewer wires make the hardware installation much easier.
- The connections are a very reliable and stable communication basis with polarity-insensitive wiring. This leads to an easier installation as well and less need for maintenance.

At the end of this document, you can find a short comparison of e:bus with DALI and DMX based communication.

general information

- Up to 8 devices connect to e:bus, organized through an additional master device.
- Free topology architecture allows the devices to be connected in combination of star, loop, daisy chain and bus structures.
- e:bus is designed for cable lengths of up to 400 meters, depending on cable type, topology and number of connected devices. A bus topology allows the largest cable length.
- Interfaces are powered via e:bus.
- Interfaces will be automatically registered and addressed.
- Defective units will not affect the communication between other devices.

bus topology

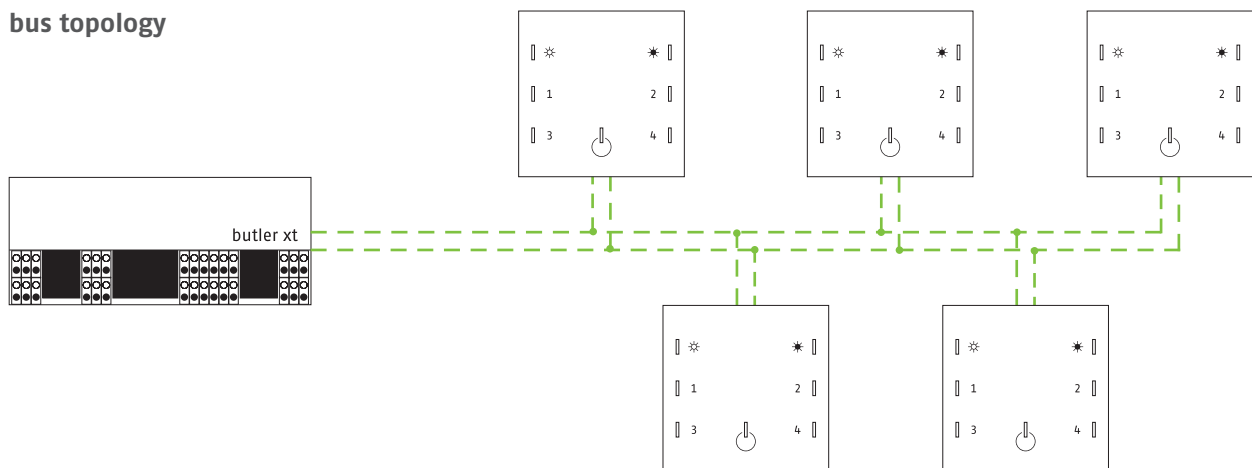

free topology

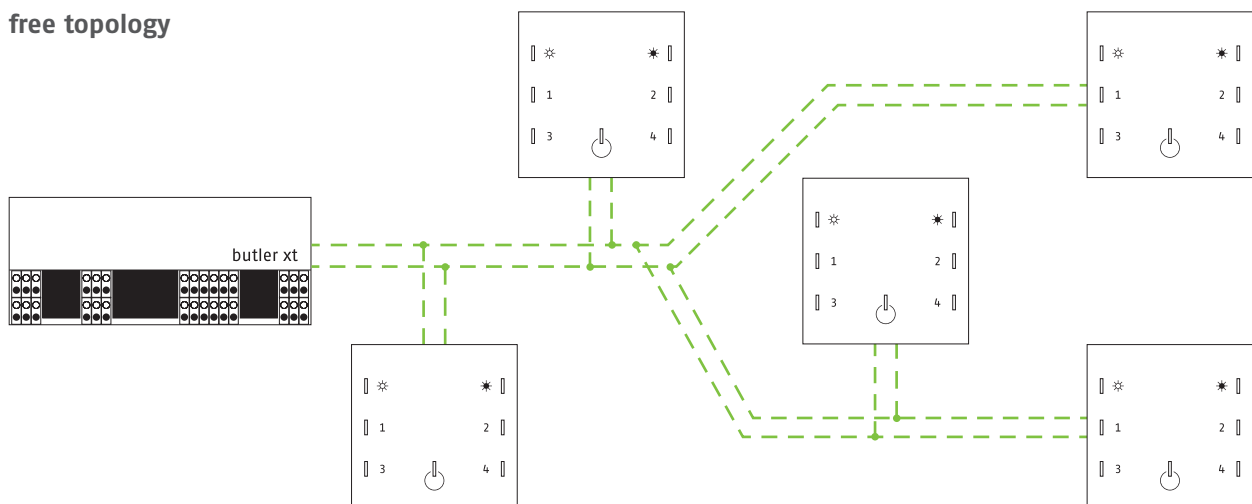

e:bus – short introduction manual

wiring

The e:bus is a 2-wire-bus system using screw terminal connectors to attach the wires safely and robust. The wiring between the devices is extremely flexible. In addition to the free topology design, you do not need to pay attention to polarities. As long as the two e:bus connectors of a user terminal are connected to the master unit's connectors, regardless if a cable goes from + to + or from + to -, everything will work fine. The two e:bus connectors of a user terminal can be connected to the master unit's connectors either way. The terminal devices will recognize the polarity on their own and configure themselves the proper way.

the following is not allowed:

- Do **not** add a second master to an e:bus network!

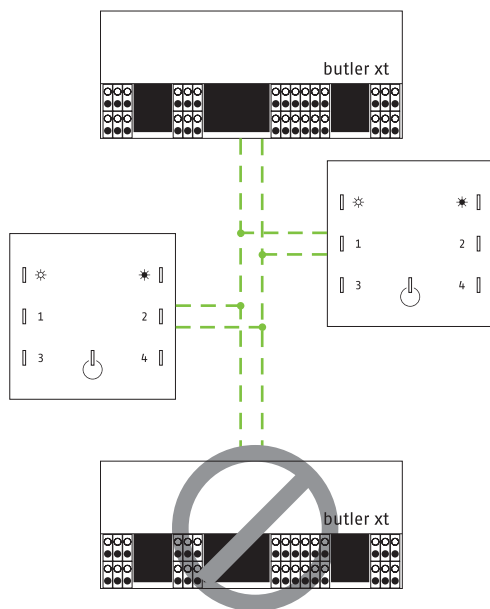

- Do **not** leave any wires open!
Open wires will cause signal reflections and therefore disrupt communication.

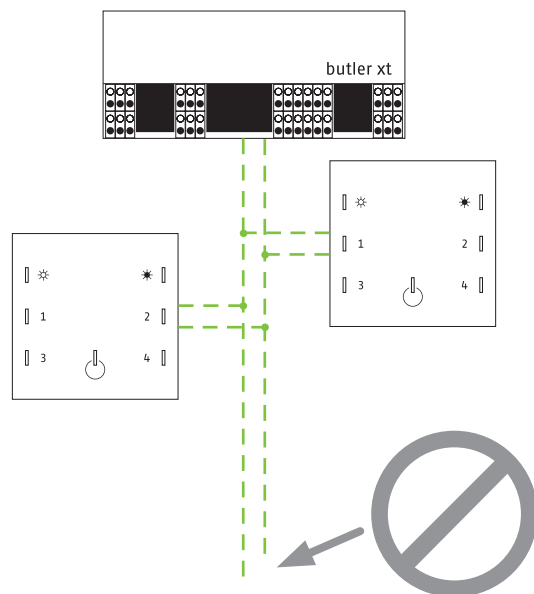

- Do **not** create short-circuits.
The + and - cables must not be directly connected!

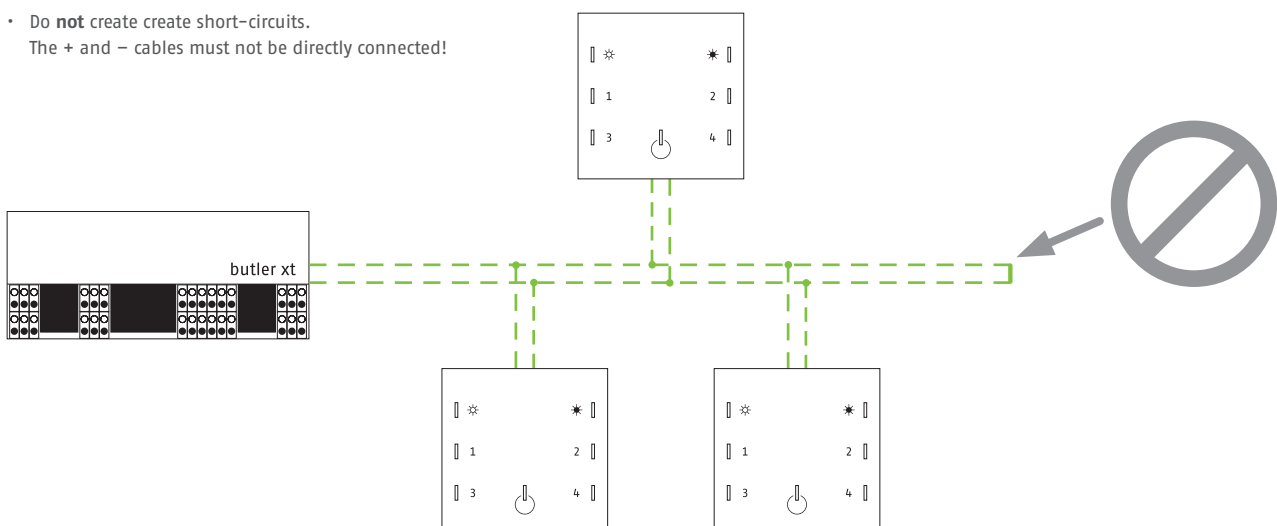

e:bus – short introduction manual

cable types & length

The maximum cable length is greatly dependent on device count, topology and cable types as well. Approved cable types for e:bus are AWG 16 (1,3 mm / 0.051") twisted pair and AWG 24 (0.511 mm / 0.02") cat 5 cables. The following table shows valuable key facts:

device count	AWG 16 (1,3 mm / 0.051") Twisted-Pair Cable		AWG 24 (0,511 mm / 0.02") Category 5 Cable	
	bus topology	free topology	bus topology	free topology
1	400 m / 1312 feet	100 m / 328 feet	400 m / 1312 feet	100 m / 328 feet
2	400 m / 1312 feet	100 m / 328 feet	268 m / 879 feet	100 m / 328 feet
4	400 m / 1312 feet	100 m / 328 feet	133 m / 436 feet	100 m / 328 feet
6	400 m / 1312 feet	100 m / 328 feet	88 m / 288 feet	82 m / 269 feet
8	400 m / 1312 feet	100 m / 328 feet	66 m / 216 feet	61 m / 200 feet

maximum cable lengths in meters and feet

comparison

e:bus offers various advantages over other communication platforms. The following table shows a comparison between the e:bus platform, DALI and RS-485 based communication:

feature	e:bus	DALI	DMX
includes protocol	✓	✓	✓
self-organizing network	✓	-	-
free topology wiring	✓	✓	-
link power	✓	-	-
polarity-insensitive	✓	-	-
high-Speed signaling	✓	-	✓

For further information please have a look at our website www.ecue.de or contact your local e:cue partner or e:cue support office.